



PascalSwitch

THE DIFFERENTIAL PRESSURE MONITORING INSTRUMENT

General Information

The Novasina PascalSwitch is a high precision instrument for monitoring pressure differences in the low range, for example in cleanroom systems.

The measurement method is based on the principle of mass flow measurement. This method requires no moving parts (e.g. diaphragm) and so enables very high accuracy, reproducibility, reliability and long-term stability. The instrument is very small and designed for cleanroom compatibility.

The gauge is available in two versions. PascalSwitch 20 is for applications in a measurement range of 0 to 20 Pa (0 to 0.08 inH₂O) and PascalSwitch 100 in a range of 0 to 100 Pa (0 to 0.4 inH₂O).

Two threshold values are freely programmable throughout the instrument range. Two integrated relays and LED's indicate when these threshold values are crossed.

As an option, a DLL (Dynamic Link Library) is available to support integration (via RS232) of the instrument (PascalSwitchC) in, for example a Building Management or Testing System.

Simple to use program, PascalTool-Palm (for OS-Version 3.0 or higher) are available to configure the relevant environmental conditions, to carry out Zero and Gain Calibration and to display online the current differential pressure.

Main Features

- No mechanical moving parts (e.g. diaphragm) in the measurement cell
- Very low accuracy error $\leq \pm 0.25\% \text{ FS}$ (full scale) or $\leq \pm 1.5\% \text{ m.V.}$ (measured value) whichever is larger
- Very low offset drift <math>< 0.1 \text{ Pa/year}</math>
- No hysteresis
- Insensitive to vibrations
- Not damaged by high differential pressures up to 2 bar
- Cleanroom compatible designed
- Two threshold, hysteresis and delay values are freely programmable
- Two integrated relays max. 2A/60W
- LED display of the two alarm points
- Easy to calibrate (Zero and Gain)
- Customer specific configuration is possible
- Quick and simple programming with PascalTool-Palm or Palm Emulator on PC
- Easy compensation of hose length by configuration software

Applications

- Monitoring the proper functioning of mini environment enclosures
- Monitoring the required pressure difference between different cleanrooms and in FOUF's
- Monitoring pressure changes in enclosures caused by leaks, defective fans or flaps etc.



Specifications

Type	PascalSwitch 20	PascalSwitch 100
Article-No.	1115961	1115962
Article-No. for PascalSwitch C	1116386	1116387
Measurement range	0 ... 20 Pa	0 ... 100 Pa
Max. resolution	0.016 Pa	0.07 Pa
Measurement interval	150 ms ... 1350 ms	150 ms ... 1350 ms
Time constant	10 ms	10 ms
Measurement accuracy (at 20°C/50%RH) (m.V. = of measured value)	< 4 Pa = ± 0.05 Pa >= 4 Pa = ±1,5% m.V.	< 17 Pa = ± 0.25 Pa >= 17 Pa = ±1.5% m.V.
Temperature effect	< 0.05% m.V./°C	< 0.05% m.V./°C
Atmospheric pressure effect (at 1013.25 hPa)	0.1% m.V./hPa	0.1% m.V./hPa
Hysteresis	0.00%	0.00%
Offset drift (at constant Temp. 20°C)	< 0.1 Pa/year	< 0.1 Pa/year
Max. permissible differential pressure	± 2 bar	± 2 bar
Max. permissible overpressure	2 bar	2 bar
Max. mass flow through the sensor	120 sccm (0.12 liter/min)	370 sccm (0.37 liter/min)
Operating temperature range	0 ... 50°C	0 ... 50°C
2 Threshold values adjustable	> or < 0.01 ... 19.99 Pa	> or < 0.01 ... 99.99 Pa
2 Relays (break- and make contacts)	max. 48V/2A and max. 60W resistive load	max. 48V/2A and max. 60W resistive load
Digital interface	useable only for configuration or PC-Communication with PSwitchDLL	
Power supply	10 ... 35 VDC	10 ... 35 VDC
Power consumption	max. 1.2 W	max. 1.2 W
Protection	IP 54 / EMC	IP 54 / EMC

Accessories

	Article-No.
External power supply 90 ... 260 VAC Euro-plug	1115966
External power supply 90 ... 260 VAC US-, Japan-plug	1115967
Connecting nozzle straight	1116332
Connecting nozzle 90°	1115968
Configuration program PascalTool-Palm	1115969
Configuration program PascalTool-Win	1116848
Development kit PSwitchDLL	1116376
Development kit PDatDLL	1117545
Programming cable to PC (DB 9)	1116849
Programming cable to Palm III and VII	1115970
Programming cable to Palm V, IBM WorkPad	1115971
Programming cable to Palm M100 and 105	1116307
Programming cable to Palm M125, 130, 5XX, 7XX	1117548
Customer specific configuration	1116074

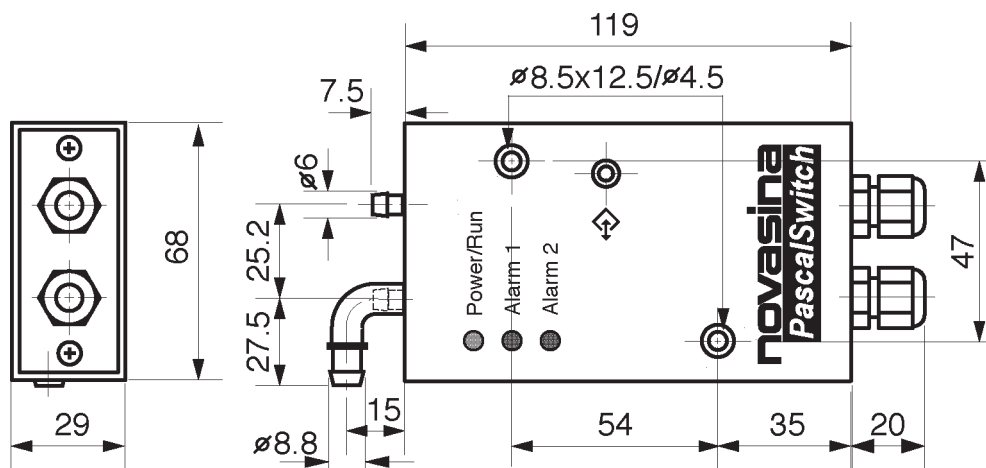



PascalDat

THE DIFFERENTIAL PRESSURE MEASUREMENT INSTRUMENT

General Information

The Novasina PascalDat is a high precision instrument for measuring and controlling pressure differences in the low range, for example in cleanroom systems. The measurement method is based on the principle of mass flow measurement. This method requires no moving parts (e.g. diaphragm) and so enables very high accuracy, reproducibility, reliability and long-term stability. The instrument is very small and designed for cleanroom compatibility.

The gauge is available in two versions. PascalDat 20 is for applications in a measurement range of -20 to +20 Pa (-0.08 to +0.08 inH₂O) and PascalDat 100 in a range of -100 to +100 Pa (-0.4 to +0.4 inH₂O).

A digital interface (RS 232) and an analog output (0 ... 10 V, 2 ... 10 V, 0 ... 20 mA or 4 ... 20 mA) indicate the pressure difference. The analog output can be configured and calibrated, so that the measurement range can be adjusted to match the signal range (e.g. 5...10 Pa = 4...20 mA) as well as to a following connected device.

Simple to use programs, PascalTool-Palm (for OS-Version 3.0 or higher) and PascalTool-Win (for Windows 95, NT or higher) are available to configure the relevant environmental conditions and to carry out Zero and Gain Calibration.

Main Features

- No mechanical moving parts (e.g. diaphragm) in the measurement cell
- Very high accuracy $< \pm 0.25\%$ FS (full scale) or $< \pm 1.5\%$ m.V. (measured value) whichever is larger
- Very low offset drift < 0.1 Pa/year
- No hysteresis
- Insensitive to vibrations
- Not damaged by high differential pressures up to 2bar
- Different output signals, selectable
- Analog output signal can be configured and calibrated
- Ease of calibration (Zero and Gain)
- Cleanroom compatible designed
- Customer specific configuration is possible
- Quick and simple programming with PascalTool-Palm or PascalTool-Win
- Easy compensation of hose length by configuration software

Applications

- Monitoring the proper functioning of mini environment enclosures
- Controlling the required pressure difference between different cleanrooms
- Monitoring pressure changes in enclosures caused by leaks, defective fans or flaps etc.



Specifications

Type	PascalDat 20	PascalDat 100
Article-No.	1115963	1115964
Measurement range	-20 ... +20 Pa	-100 ... +100 Pa
Max. resolution	0.016 Pa	0.07 Pa
Measurement interval	150 ms ... 1350 ms	150 ms ... 1350 ms
Time constant	10 ms	10 ms
Measurement accuracy (at 20°C/50%RH) (m.V. = of measured value)	< 4 Pa = ± 0.05 Pa >= 4 Pa = ±1,5% m.V.	< 17 Pa = ± 0.25 Pa >= 17 Pa = ±1.5% m.V.
Temperature effect	< 0.05% m.V./°C	< 0.05% m.V./°C
Atmospheric pressure effect (at 1013.25 hPa)	0.1% m.V./hPa	0.1% m.V./hPa
Hysteresis	0.00%	0.00%
Offset drift (at constant Temp. 20°C)	< 0.1 Pa/year	< 0.1 Pa/year
Max. permissible differential pressure	± 2 bar	± 2 bar
Max. permissible overpressure	2 bar	2 bar
Max. mass flow through the sensor	120 sccm (0.12 liter/min)	370 sccm (0.37 liter/min)
Operating temperature range	0 ... 50°C	0 ... 50°C
Analog output (configurable and calibratable)	0 ... 10 V, 2 ... 10 V (load to ground >10 kOhm) 0 ... 20 mA, 4 ... 20 mA (load <500 Ohm)	
Digital interface	RS 232 (ASCII-string or complex protocol)	
Power supply	10.5 ... 35 VDC	10.5 ... 35 VDC
Power consumption	max. 3 W	max. 3 W
Protection	IP 54 / EMC	IP 54 / EMC

Accessories

	Article-No.
External power supply 90 ... 260 VAC Euro-plug	1115966
External power supply 90 ... 260 VAC US-, Japan-plug	1115967
Connecting nozzle straight	1116332
Connecting nozzle 90°	1115968
Configuration program PascalTool-Palm	1115969
Configuration program PascalTool-Win	1116848
Development kit PSwitchDLL	1116376
Development kit PDatDLL	1117545
Programming cable to PC (DB 9)	1116849
Programming cable to Palm III and VII	1115970
Programming cable to Palm V, IBM WorkPad	1115971
Programming cable to Palm M100 and 105	1116307
Programming cable to Palm M125, 130, 5XX, 7XX	1117548
Customer specific configuration	1116074

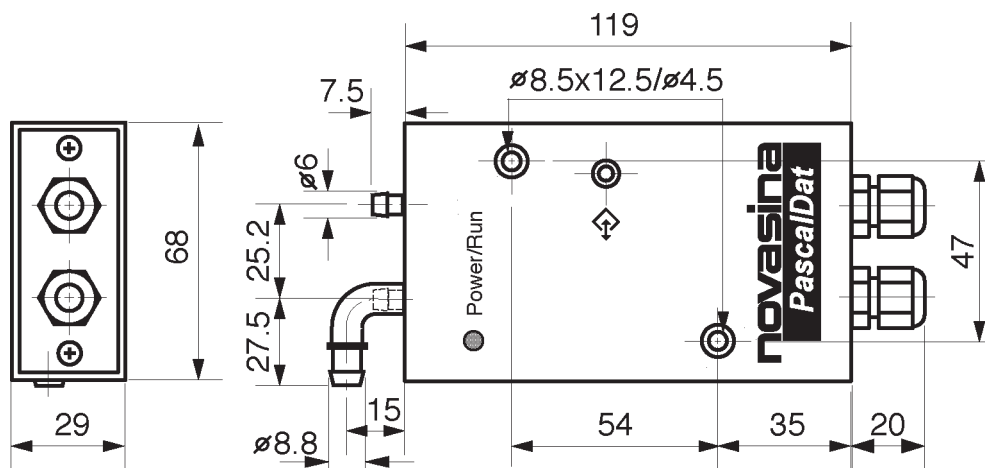

PascalVision

THE DIFFERENTIAL PRESSURE DISPLAY INSTRUMENT



General Information

The Novasina PascalVision is a high precision instrument for measuring, controlling and to display pressure differences in the low range, for example in cleanroom systems. The measurement method is based on the principle of mass flow measurement. This method requires no moving parts (e.g. diaphragm) and so enables very high accuracy, reproducibility, reliability and long-term stability. The instrument is very small and designed for cleanroom compatibility.

The gauge is available in two versions. PascalVision 20 is for applications in a measurement range of -20 to +20 Pa (-0.08 to +0.08 inH₂O) and PascalVision 100 in a range of -100 to +100 Pa (-0.4 to +0.4 inH₂O).

A two line LCD-Display indicates the current

differential pressure. The display is protected by a transparent casting and its brightness is adjustable.

A digital interface (RS 232) and an analog output (0 ... 10 V, 2 ... 10 V, 0 ... 20 mA or 4 ... 20 mA) indicate the pressure difference. The analog output can be configured and calibrated, so that the measurement range can be adjusted to match the signal range (e.g. 5...10 Pa=4...20 mA) as well as to the connected device.

Simple to use programs, PascalTool-Palm (for OS-Version 3.0 or higher) and PascalTool-Win (for Windows 95, NT or higher) are available to configure the relevant environmental conditions and to carry out Zero and Gain Calibration.

Main Features

- Current differential pressure indicated on a LCD-Display
- No mechanical moving parts (e.g. diaphragm) in the measurement cell
- Very high accuracy $< \pm 0.25\%$ FS (full scale) or $< \pm 1.5\%$ m.V. (measured value) whichever is larger
- Very low offset drift < 0.1 Pa/year
- No hysteresis
- Insensitive to vibrations
- Not damaged by high differential pressures up to 2bar
- Different output signals, selectable
- Analog output signal can be configured and calibrated
- Ease of calibration (Zero and Gain)
- Cleanroom compatible designed
- Customer specific configuration is possible
- Quick and simple programming with PascalTool-Palm or PascalTool-Win
- Easy compensation of hose length by configuration software

Applications

- Monitoring the proper function-ing of mini environment enclosures
- Controlling the required pressure difference between different cleanrooms
- Monitoring pressure changes in enclosures caused by leaks, defective fans or flaps etc.



Specifications

Type	PascalVision 20	PascalVision 100
Article-No.	1116844	1116845
Measurement range	-20 ... +20 Pa	-100 ... +100 Pa
Max. resolution	0.016 Pa	0.07 Pa
Measurement interval	150 ms ... 1350 ms	150 ms ... 1350 ms
Time constant	10 ms	10 ms
Measurement accuracy (at 20°C/50%RH) (m.V. = of measured value)	< 4 Pa = ± 0.05 Pa >= 4 Pa = ±1,5% m.V.	< 17 Pa = ± 0.25 Pa >= 17 Pa = ±1.5% m.V.
Temperature effect	< 0.05% m.V./°C	< 0.05% m.V./°C
Atmospheric pressure effect (at 1013.25 hPa)	0.1% m.V./hPa	0.1% m.V./hPa
Hysteresis	0.00%	0.00%
Offset drift (at constant Temp. 20°C)	< 0.1 Pa/year	< 0.1 Pa/year
Max. permissible differential pressure	± 2 bar	± 2 bar
Max. permissible overpressure	2 bar	2 bar
Max. mass flow through the sensor	120 sccm (0.12 liter/min)	370 sccm (0.37 liter/min)
Operating temperature range	0 ... 50°C	0 ... 50°C
Analog output (configurable and calibratable)	0 ... 10 V, 2 ... 10 V (load to ground >10 kOhm) 0 ... 20 mA, 4 ... 20 mA (load <500 Ohm)	
Digital interface	RS 232 (ASCII-string or complex protocol)	
Power supply	10.5 ... 35 VDC	10.5 ... 35 VDC
Power consumption	max. 3 W	max. 3 W
Protection	IP 54 / EMC	IP 54 / EMC

Accessories

	Article-No.
External power supply 90 ... 260 VAC Euro-plug	1115966
External power supply 90 ... 260 VAC US-, Japan-plug	1115967
Connecting nozzle straight	1116332
Connecting nozzle 90°	1115968
Configuration program PascalTool-Palm	1115969
Configuration program PascalTool-Win	1116848
Development kit PSwitchDLL	1116376
Development kit PDatDLL	1117545
Programming cable to PC (DB 9)	1116849
Programming cable to Palm III and VII	1115970
Programming cable to Palm V, IBM WorkPad	1115971
Programming cable to Palm M100 and 105	1116307
Programming cable to Palm M125, 130, 5XX, 7XX	1117548
Customer specific configuration	1116074

