

# Basler IP Cameras

## Security Cameras Overview



- Superior image quality
- Industrial-grade reliability
- Megapixel
- High sensitivity CCD sensor technology
- Efficient H.264 compression

**BASLER**  
VISION TECHNOLOGIES  
*click. see. smile!*

## Features and Benefits

The Basler IP Camera product line offers flexible, high-performance solutions for a wide range of applications in the area of video surveillance. Our cameras meet the market's requirements for exceptional image quality and an excellent price/performance ratio.

Basler IP Cameras use the best available CCD sensors and incorporate concepts specifically adapted to surveillance tasks. The outstanding performance of these cameras is a direct result of Basler's 20 years of experience in industrial image processing.

### All Basler IP Cameras have the following performance characteristics:

#### Multi-encoding

Only Basler IP Cameras offer the full range of video compression techniques, including standards-compliant MJPEG, MPEG-4, or H.264. Simultaneous independent streaming using different encoders provides a perfect fit for the varied requirements of users and clients. While MJPEG can deliver exceptional image quality for uses such as evidence data, MPEG-4 or H.264 can be used for lower bandwidth consumption at even higher frame rates.

#### Multi-streaming

Multiple streams can be set up while deploying the full set of encoders. This approach allows, for example, the customized use of multiple MJPEG streams while also using an MPEG-4 or H.264 encoded stream. The resolution and frame rate of the MJPEG image streams and the MPEG-4 or H.264 stream can be adjusted independently.

#### Scaling and AOI feature

To display a maximum of detail with the highest precision, several image formats and any aspect ratio can be configured. The unique Area of Interest (AOI) feature lets users define customized regions within the original field of view. The selected areas of interest can be streamed and encoded separately to realize not only ePTZ but also multiple virtual cameras. This means that only relevant image details will be transmitted, avoiding redundant data and leading to a significant reduction in the bandwidth required while maximizing storage utilization.



#### Progressive scan

Basler IP Cameras incorporate CCD image sensors employing the progressive scan method, which is the basis for exceptional image quality with reduced motion blur. The advantage of progressive scan is not only the higher vertical resolution but also the absence of the visual artifacts associated with interlaced cameras. Progressive scan leads to sharper, clearer images.

#### Ideal image quality

A flexible set of control functions ensures outstanding quality images for a variety of applications. Configurable measurement windows for exposure control make it possible to maintain optimal brightness for a scene. White balance can either be automatically controlled or manually adjusted resulting in ideal color fidelity. Configurable gain control, an iris drive with DC control, and the incorporation of highly sensitive CCD sensors guarantee the best representation of objects under surveillance, especially if lighting conditions are poor or changing.

#### Day & night functionality

True day and night functionality via an automatically retractable IR-cut filter provides a high image quality color mode for daylight applications and a black and white mode for night and low light conditions.

#### Motion detection and intelligent alarm buffering

Using an array of 32 x 24 definable fields, the user can generate up to five different masks. Motion detection can be combined with extensive event and alarm management functionality. Configurable internal ring buffer storage makes it possible to access pre and post alarm images, even if no stream was sent to a client.

### Basler IP Fixed Cameras

#### Small and versatile

Basler IP Fixed Cameras for security applications come in a wide range of resolutions from VGA to two megapixels. They are equipped with a CS-mount with DC iris drive, so you can choose from a whole range of camera lenses to integrate the most suitable one for your security needs.



An ultra-compact, all-metal housing with an 89.8 mm x 29 mm x 44 mm size and a weight of only 230 grams makes these the smallest IP cameras in their class. These characteristics contribute to their flexibility and ease of installation.



All components used in Basler IP Cameras are specifically selected to form a high quality, "made in Germany" product.

Please contact us for information about accessories available for Basler IP Fixed Cameras. We offer a wide variety of lenses and outdoor housings.

### Basler IP Fixed Dome Cameras

#### Tough and flexible

Basler IP Fixed Dome Cameras are equipped with vandal-resistant aluminum housings, allowing video surveillance applications outdoors and under tough indoor conditions. With their built-in heater and fan, Basler Dome Cameras work at extreme operating temperatures from -35° to +50° C (-31° to +122° F).



Basler IP Fixed Dome Cameras are especially energy efficient. All camera functions, including the fan and heater, can be powered using standard PoE (Power over Ethernet IEEE 802.3af Class 0). Basler IP Fixed Dome Cameras have a built-in micro SDHC card slot that can be used for local file storage.

Basler Dome Cameras can be easily mounted to a wall or a ceiling, and an internal three-axis camera bracket allows complete flexibility when aiming the camera. For optimal mounting, our accessories portfolio includes a suspended ceiling kit and a wall bracket kit.



## Specifications



Basler IP Camera	BIP-640c (BIP-640c-dn)	BIP-1000c (BIP-1000c-dn)
Image Sensor	1/3" Sony Wfine progressive scan RGB CCD	
Effective Pixels	640 (H) x 480 (V)	
Frame Rate (max.)	MJPEG      MPEG-4      H.264	MJPEG      MPEG-4      H.264
Full Resolution:	30 fps      30 fps      25 fps	18 fps      11 fps      10 fps
D1 (720 x 480):	30 fps*      30 fps*      25 fps*	30 fps      30 fps      25 fps
	Max sensor readout rate: 71 fps	Max sensor readout rate: 30 fps
Pixel Size	7.4 μm x 7.4 μm	
Day/Night	Removable IR-Cut Filter (BIP-640c-dn)	
Minimum Illumination	Color: 0.35 lux (F1.0/33ms), Day/Night: 0 lux (with IR illumination)	
Lens	CS-mount, DC iris drive (lens not included)	
Image Settings	Automatic gain, exposure area, backlight compensation, white balance, electronic shutter; anti-flicker; 180° image rotation, electronic PTZ via AOI (API), text overlay, privacy masks, motion detection	
Resolution	From 64 x 64 to 640 x 480 (free scaling), 4:3, 16:9, multiple Areas of Interest (AOIs)	From 64 x 64 to 1024 x 768 (free scaling), 4:3, 16:9, multiple Areas of Interest (AOIs)
Video Compression	Motion JPEG: Multiple compression levels MPEG-4: SP (Level 3) H.264 (MPEG-4 AVC): Baseline (Level 3)	
Video Streaming	Simultaneous dual encoding for MJPEG and MPEG-4 or H.264, multi-streaming for MJPEG, VBR and CBR for MJPEG, MPEG-4 and H.264, multicast and unicast	
Alarm Management	Ring buffer for pre and post alarm Events triggered by motion detection, or external input Image upload over FTP, Email, or HTTP	
Protocols	TCP/IP, HTTP, FTP, UDP, ICMP, ARP, DHCP, NTP, RTP, RTSP, RTCP, SMTP, IGMP, ZEROCONF, QoS Layer 3	
Processor/Memory	600 MHz dual-core multimedia DSP, FPGA, 128 MB RAM, 8 MB Flash	
Power	PoE (Power over Ethernet IEEE 802.3af Class 2) or 7 to 20VDC, power consumption is 5 W max. at 12 VDC	
Connectors	RJ-45 connector for 10/100 BASE-T Ethernet, full or half duplex 6 pin terminal for DC power; digital I/O and RS-232	
Operating Conditions	0° to 50° C (32° to 122° F), < 90 % relative humidity (non-condensing)	
Standards	DIN EN 50130-4, FCC Class B, CE, RoHS	
Housing	89.8 mm x 29 mm x 44 mm (full metal casing)	
Weight	~230 g	

Specifications are subject to change without prior notice.

## Dimensions in mm (inch)

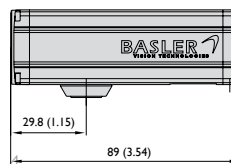
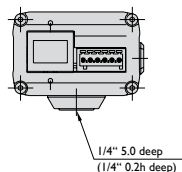
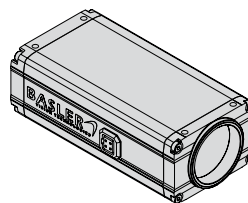
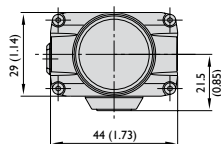

# TECHNICAL DETAILS

## Specifications



Basler IP Camera	BIP-1300c (BIP-1300c-dn)	BIP-1600c (BIP-1600c-dn)
Image Sensor	1/3" Sony EXview HAD progressive scan RGB CCD	1/1.8" Sony Wfine progressive scan RGB CCD
Effective Pixels	1280 (H) x 960 (V)	1600 (H) x 1200 (V)
Frame Rate (max.)	MJPEG      MPEG-4      H.264	MJPEG      MPEG-4      H.264
Full Resolution:	11 fps      9 fps      7 fps	8 fps      5 fps      4 fps
DI (720 x 480):	30 fps      25 fps      25 fps	30 fps*      25 fps*      25 fps*
	Max sensor readout rate: 30 fps	Max sensor readout rate: 12.5 fps <span style="float:right">*via AOI</span>
Pixel Size	3.75 μm x 3.75 μm	4.4 μm x 4.4 μm
Day/Night	Removable IR-Cut Filter (BIP-1300c-dn)	Removable IR-Cut Filter (BIP-1600c-dn)
Minimum Illumination	Color: 0.95 lux (F1.0/33ms), Day/Night: 0 lux (with IR illumination)	Color: 0.83 lux (F1.4/33ms), Day/Night: 0 lux (with IR illumination)
Lens	CS-mount, DC iris drive (lens not included)	C-mount with adapter ring (BIP-1600c: lens not included) BIP-1600c-dn (lens included): DC-iris-IR 1.4/10-40 mm
Image Settings	Automatic gain, exposure area, backlight compensation, white balance, electronic shutter, anti-flicker; 180° image rotation, electronic PTZ via AOI (API), text overlay, privacy masks, motion detection	
Resolution	From 64 x 64 to 1280 x 960 (free scaling), 4:3, 16:9, multiple Areas of Interest (AOIs)	From 64 x 64 to 1600 x 1200 (free scaling), 4:3, 16:9, multiple Areas of Interest (AOIs)
Video Compression	Motion JPEG: Multiple compression levels MPEG-4: SP (Level 3) H.264 (MPEG-4 AVC): Baseline (Level 3)	
Video Streaming	Simultaneous dual encoding for MJPEG and MPEG-4 or H.264, multi-streaming for MJPEG, VBR and CBR for MJPEG, MPEG-4 and H.264, multicast and unicast	
Alarm Management	Ring buffer for pre and post alarm Events triggered by motion detection, or external input Image upload over FTP, Email, or HTTP	
Protocols	TCP/IP, HTTP, FTP, UDP, ICMP, ARP, DHCP, NTP, RTP, RTSP, RTCP, SMTP, IGMP, ZEROCONF, QoS Layer 3	
Processor/Memory	600 MHz dual-core multimedia DSP, FPGA, 128 MB RAM, 8 MB Flash	
Power	PoE (Power over Ethernet IEEE 802.3af Class 2) or 7 to 20VDC, power consumption is 5 W max. at 12 VDC	
Connectors	RJ-45 connector for 10/100 BASE-T Ethernet, full or half duplex 6 pin terminal for DC power, digital I/O and RS-232	
Operating Conditions	0° to 50° C (32° to 122° F), < 90 % relative humidity (non-condensing)	
Standards	DIN EN 50130-4, FCC Class B, CE, RoHS	
Housing	89.8 mm x 29 mm x 44 mm (full metal casing)	
Weight	~230 g	

Specifications are subject to change without prior notice.

## Architecture

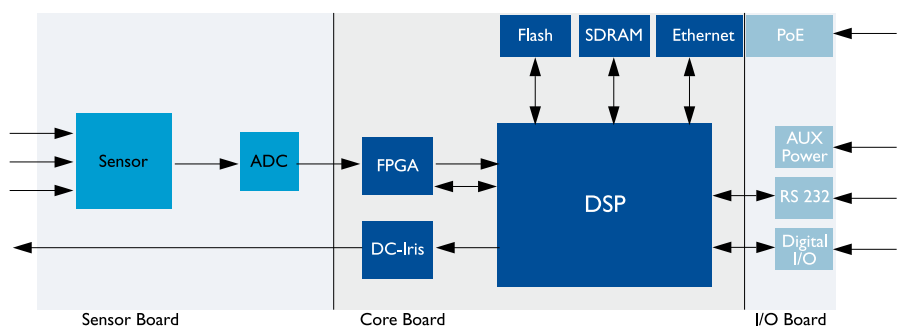

## Specifications



Basler IP Camera	BIP-D1000c-dn	BIP-D1300c-dn
Image Sensor	1/3" Sony Wfine progressive scan RGB CCD	
Effective Pixels	1024 (H) x 768 (V)	
Frame Rate (max.)	MJPEG      MPEG-4      H.264	MJPEG      MPEG-4      H.264
Full Resolution:	18 fps      11 fps      10 fps	11 fps      9 fps      7 fps
DI (720 x 480):	30 fps      30 fps      25 fps	30 fps      25 fps      25 fps
	Max sensor readout rate: 30 fps	
Pixel Size	4.65 μm x 4.65 μm	
Minimum Illumination	Color: 1.7 lux (F1.3/33ms), Day/Night: 0 lux (with IR illumination)	
Lens	Varifocal 2.8 - 10 mm, F1.3, DC iris, horizontal angle of view 20° - 80°, removable IR-cut filter for day/night function	
Camera Angle Adjustment	Pan: ±180°, tilt: 120°, rotation: 360°	
Image Settings	Automatic gain, exposure area, backlight compensation, white balance, electronic shutter, anti-flicker, 180° image rotation, electronic PTZ via AOI (API), text overlay, privacy masks, motion detection	
Resolution	From 64 x 64 to 1024 x 768 (free scaling), 4:3, 16:9, multiple Areas of Interest (AOIs)	From 64 x 64 to 1280 x 960 (free scaling), 4:3, 16:9, multiple Areas of Interest (AOIs)
Video Compression	Motion JPEG: Multiple compression levels MPEG-4: SP (Level 3) H.264 (MPEG-4 AVC): Baseline (Level 3)	
Video Streaming	Simultaneous dual encoding for MJPEG and MPEG-4 or H.264, multi-streaming for MJPEG, VBR and CBR for MJPEG, MPEG-4 and H.264, multicast and unicast	
Alarm Management	Ring buffer for pre and post alarm, microSDHC card slot for local storage Events triggered by motion detection or external input Image upload over FTP, e-mail, or HTTP	
Protocols	TCP/IP, HTTP, UDP, FTP, ICMP, ARP, DHCP, NTP, RTP, RTSP, RTCP, SMTP, IGMP, ZEROCONF, QoS Layer 3	
Processor/Memory	600 MHz dual-core multimedia DSP, FPGA, 128 MB RAM, 8 MB Flash	
Power	PoE (Power over Ethernet IEEE 802.3af Class 0) or 7 to 24VDC, power consumption is 7W max at 12VDC (excl. heater)	
Connectors	RJ-45 connector for 10/100 BASE-T Ethernet, full or half duplex Push-in terminal for DC power, digital I/O and RS-485/422	
Operating Conditions	-35° to 50° C (-31° to 122° F), < 90 % relative humidity (non-condensing)	
Standards	DIN EN 50130-4, FCC Class A, CE, RoHS	
Housing	Ø 148 mm x 122 mm (Ø 5.83" x 4.8") aluminum chassis with polycarbonate dome bubble, IP66, IK10	
Weight	~1.0 kg	

Specifications are subject to change without prior notice.

## Dimensions in mm (inch)

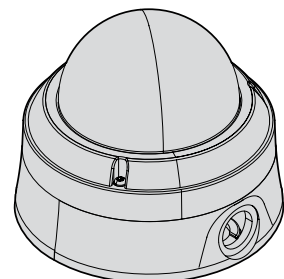
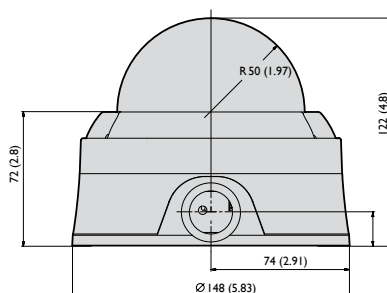

# What Makes Basler Camera Quality So Special?

To ensure consistently high product quality, we employ several inspection procedures during manufacturing. The following list indicates three of the most important quality assurance tools we use to meet your highest requirements.

### Camera Sensor Alignment Tool (CSAT):

Due to higher resolutions and smaller pixels, depth of focus and the exact positioning of the imaging sensor in the camera are becoming more and more critical. An area scan sensor must be aligned in six degrees of freedom.

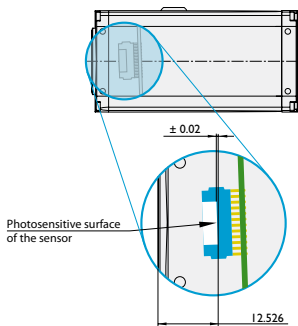

The back focal length on each camera is carefully measured and adjusted by our unique "CSAT" procedure. This guarantees an optimum distance between the lens flange and the sensor and ensures outstanding image quality based on compliance with optics standards.

### Temperature Test

As a final check, each camera pass a stress test. Cameras are tested over the entire temperature range specified in our documentation. By doing this, we can identify and remove temperature sensitive weak spots in the camera. This guarantees consistent image quality in conditions with quickly changing temperatures.

### Camera Test Tool (CTT+)

Our advanced Camera Test Tool (CTT+), the first fully automated inspection system for digital cameras, checks all of the significant quality aspects of each camera we produce. The CTT+ is a unique combination of optics, hardware, and software that can be quickly and efficiently used to calibrate a camera and to measure its performance against a set of standards. For defined sets of conditions, an automated software program examines the camera's output, makes any calibration adjustments necessary, and compares the output to a strictly defined set of performance criteria.

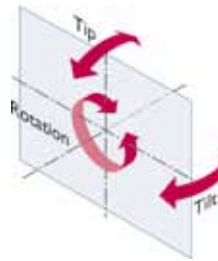

Basler customers get a 100% tested camera, all of the benefits that go along with 100% testing, and a much higher level of satisfaction. This is a definite win-win situation.

## RoHS Compliance

The Basler IP Camera series is RoHS compliant. This is especially important in applications where the end user requires strict RoHS compliance in all system components.



## About Basler

Basler Vision Technologies is one of the world's leading vision technology companies. Founded in 1988, Basler has grown to a 300+ employee company with headquarters in Germany and subsidiaries in the USA, Singapore, and Taiwan. Our success is based on the excellent quality of our products, an unwavering focus on our customers, and continuous improvements in our processes. Basler is an ISO 9001:2000 certified company.



Basler Components is the largest division of Basler Vision Technologies. Since 1997, Basler Components has been designing, manufacturing, and selling leading-edge digital cameras for industrial, medical, and surveillance applications.

Our unique combination of digital camera design experience and image processing expertise lets us both follow and influence the market trend toward more intelligent IP camera products.



## Why Basler IP Cameras?

Basler IP Cameras differentiate themselves through excellent image quality. When an event occurs, Basler IP Cameras offer you the highest image quality and maximum information.

Versatility, simplicity and comprehensive documentation make our products easy to use. Basler IP Cameras shorten your installation time and lower the barriers to a switch from analog to digital technology.

Our cameras are rich in useful features. Using Basler IP Cameras saves network costs and increases the performance (event guarantee and scalability) of your video surveillance solution.

Designed and manufactured in Germany, our products are robust and reliable. Each camera goes through an exhaustive individual inspection and calibration process before delivery. The highest reliability virtually eliminates any reinstallation efforts.

Our excellent service and support make you feel confident and comfortable about making Basler your camera vendor of choice. Our primary goal is to make you feel at home doing business with professionals devoted to developing and producing reliable, easy-to-use products featuring cutting-edge technology.



**Germany, Headquarters**  
Phone +49 4102 463 500  
Fax +49 4102 463 599  
[bc.sales.europe@baslerweb.com](mailto:bc.sales.europe@baslerweb.com)

**USA**  
Phone +1 610 280 0171  
Fax +1 610 280 7608  
[bc.sales.usa@baslerweb.com](mailto:bc.sales.usa@baslerweb.com)

**Singapore**  
Phone +65 6425 0472  
Fax +65 6425 0473  
[bc.sales.asia@baslerweb.com](mailto:bc.sales.asia@baslerweb.com)

**Japan**  
Phone +81 45 227 6210  
Fax +81 45 227 6220  
[ip.sales.asia@baslerweb.com](mailto:ip.sales.asia@baslerweb.com)

**Korea**  
Phone +82 707 1363 114  
Fax +82 707 0162 705  
[ip.sales.asia@baslerweb.com](mailto:ip.sales.asia@baslerweb.com)

**Taiwan**  
Phone +886 3 558 3955  
Fax +886 3 558 3956  
[ip.sales.asia@baslerweb.com](mailto:ip.sales.asia@baslerweb.com)