

# WMP-171/172

## Medical Grade All-in-one Solution



**Web camera**

: USB2.0 1.3M module

**TV tuner**

: PCI type  
(NTSC/PAL/SECAM)

**Wireless LAN**

: MiniPCI interface 802.11b/g  
with build in antenna

### Features

- 17" medical grade panel PC
- Medical certification compliance (EN60601-1 / UL60601-1)
- Anti-bacteria coating
- High Performance Intel Core 2 Duo Mobile Processor
- Supports PCI Expansion
- HDD Anti-vibration mechanism
- IP65(IP65 at front panel) / IPX1 compliance
- WebCAM (Optional)
- Supports 802.11b/g Wireless Solution with internal antenna (Optional)
- Fanless Design (WMP-172)
- Lower Noise Fan Design (WMP-171)

## System

<b>CPU</b>	Intel® Core™ 2 Duo 2.2G CPU (WMP-171) Intel® Core™ 2 Duo 1.06G CPU (WMP-172)
<b>FSB</b>	533MHz / 800MHz
<b>Chipset</b>	Intel® GME965 chipset + ICH8M
<b>BIOS</b>	Award BIOS, ACPI supported
<b>VGA</b>	Intel® GME965 integrated VGA (X3100)
<b>DVI</b>	One DVI 29 pin output
<b>Audio</b>	Realtek ALC286 Audio Codec, 2+2 watts power amplifier
<b>LAN</b>	Realtek RTL8111B Gigabit Ethernet x 2
<b>Memory</b>	Two Dual Channel DDR2 SODIMM socket supports up to 4GB (Default: 512M)
<b>I/O</b>	ICH8M
<b>Serial ATA</b>	Port x 1 with 150 MB/s transfer rate x 1
<b>USB</b>	8 USB 2.0 ports (4 ports in the rear I/O region, 2 ports with on-board pin headers, and 2 reserve for WebCAM and Touch screen.)
<b>WDT</b>	Generates system reset; 256 segments, 0, 1, 2...255 sec.

### Expansion

<b>PCI x1</b>	PCI 2.2 expansion slot x 1
<b>PCMCIA</b>	PCMCIA Type I/II 32-bit CardBus slot x 1
<b>Mini-PCI</b>	32-bit Mini-PCI socket x 1

### External I/O

<b>VGA</b>	DB-15 x 1
<b>DVI</b>	DVI output x 1
<b>Audio Jack</b>	3.5mm phone jack connector (Line-in, Line-out, and Mic-in)
<b>USB</b>	USB 2.0 x 4
<b>COM</b>	DB-9 x 3
<b>KB/Mouse</b>	PS/2 Connector x2 for keyboard/mouse
<b>LAN</b>	RJ45 x2 for Gigabit Ethernet
<b>Power</b>	DC-In connector x 1
<b>Switch</b>	Reset key
<b>Speaker</b>	2W x 2
<b>Front Bezel</b>	LED Indicator/ Hot Key (Power Button/ Audio adjustment +/- / brightness +/-)

### Display and Touch

<b>Panel</b>	17", 400 nits
<b>Touch</b>	Resistive type

### Storage

<b>HDD</b>	2.5" SATA HDD drive bay x 1 (with anti-vibration mechanism) (Default: 80G)
<b>CF</b>	1 x bootable Compact Flash slot for CF type I/II storages (Optional CF card)

### Mechanical & Environmental

<b>Power Input</b>	DC12V
<b>Power Adapter</b>	AC 90 ~ 264V / 47 ~ 63 Hz / DC output 12V
<b>Operation Temperature</b>	0~40°C
<b>Storage Temperature</b>	-20~80°C
<b>Operation Relative Humidity</b>	10%~90%, non-condensing
<b>Storage Relative Humidity</b>	10%~90%, non-condensing
<b>Dimensions</b>	420 x 360 x 83mm ( W x H x D)
<b>Weight</b>	7 kg without AC adapter
<b>Mounting</b>	VESA Mount 75/100mm
<b>IP65 at front / IPX1 compliance</b>	
<b>Kensington lock hole</b>	

### Fully-integrated I/O

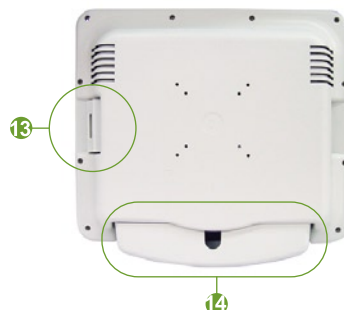
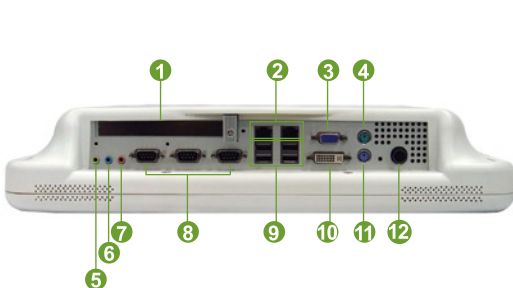

- |             |                |
|-------------|----------------|
| ① PCI Slot  | ⑨ USB          |
| ② Giga LAN  | ⑩ DVI          |
| ③ VGA       | ⑪ PS2 K/B      |
| ④ PS2 Mouse | ⑫ Power DC-in  |
| ⑤ Line-out  | ⑬ Rubber cover |
| ⑥ Line-in   | ⑭ I/O cover    |
| ⑦ Mic       |                |
| ⑧ RS232     |                |

# Medical Grade All-in-one Solution

Drawing

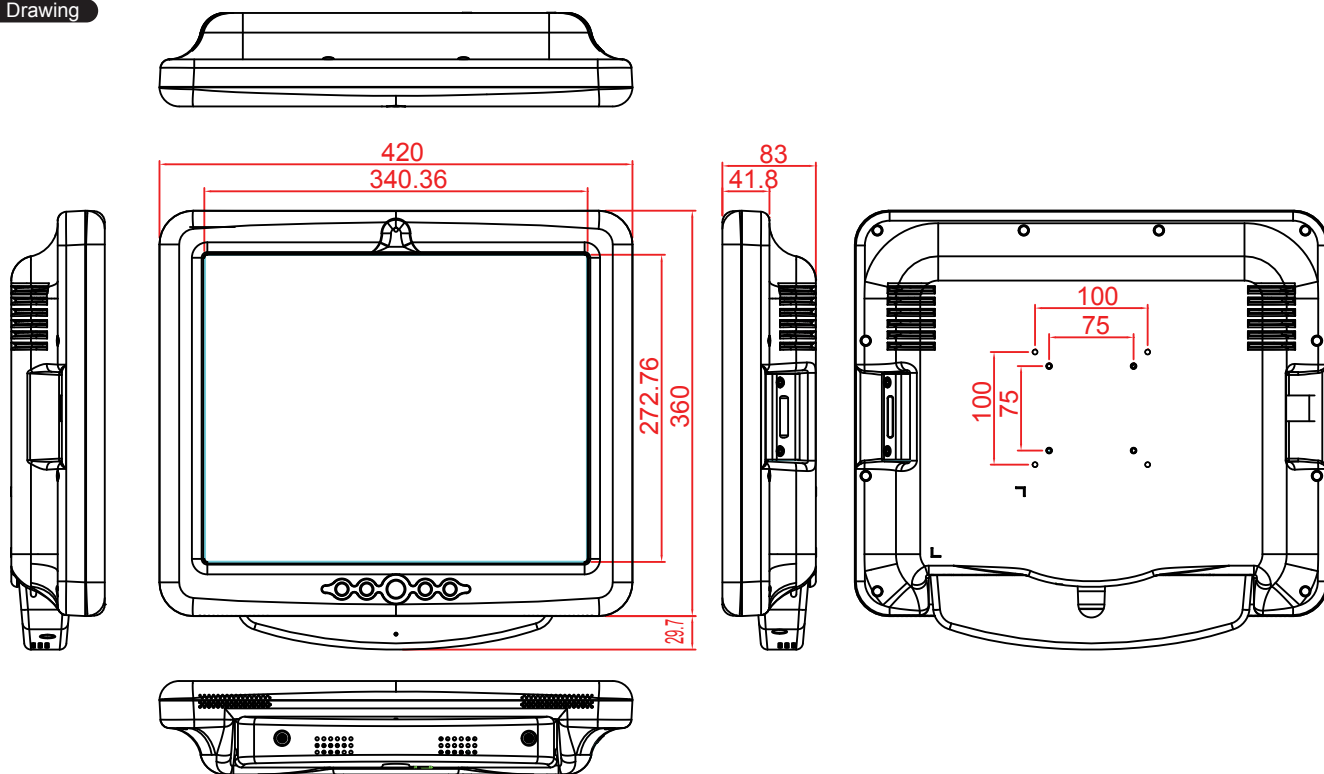

Application:



Nursing Cart



Bed Side Terminal

## Certificate

1. Regulatory : CE/FCC class B / EN60601-1/ UL60601-1, UL/cUL, VCCI
2. Water/Dust proof : IP65 at front side / IPX1

## Key Features



Truly Fanless



HDD Anti-vibration



Wireless LAN



TV tuner

## Ordering information

1. WMP-171: C2D 2.20G Mobile CPU-512M RAM-80G HDD
2. WMP-172: C2D 1.06G Mobile CPU-512M RAM-80G HDD

1. Fanless Panel PC

2. Medical All-in-one Solution

3. Engine Box

4. All-in-one Digital Signage Solution

5. XPe Solution

6. Remote Device Management (WRDM)