



More Precision.

scanCONTROL 2710

Compact 2D/3D profile sensor for beads, grooves, edges & angles





- Compact design with integrated controller
- Profile evaluation for the time of flight sensor
- 100Hz profile frequency at full resolution
- Dynamic tracking
- More than 20 measured values for over 50 standard measurement tasks

Application

The scanCONTROL 2710 system provides a complete solution for simple measurement tasks. Angles, steps and positions can be recognised and tracked. However, more demanding tasks such as the detection of beading (e.g. adhesive beads, weld seams) or grooves (e.g. channels, gaps) are also possible with dynamic tracking.

The sensor also enables the user to assess the measured values in real time and provides control signals if tolerances are exceeded. The scanCONTROL 2710 can be configured easily using the configuration software included as standard.

Function and measurement principle

The scanCONTROL 2710 laser line scanner uses the triangulation principle for two-dimensional acquisition of profiles on a wide variety of target surfaces.

For this, a static laser line is projected onto the target surface. A high quality optical camera system projects the diffuse reflected light from this laser line onto a highly sensitive sensor matrix.

The sensor calculates profile data from the camera image and the relevant characteristic values from the profile data. These values are evaluated directly (RS422 / analogue) or with tolerances and are output as (digital) switching signals.

Compact design and high speed

The scanCONTROL 2710 combines technology and performance in a single device and therefore provides a sensor design with integrated controller and compact dimensions. After the sensor has been configured using the set-up software supplied, the system operates in standalone mode and can be directly connected to a controller. Using the integrated controller, the sensor acquires the data, calculates the profile and obtains measured values for the complete measurement field and at full resolution with a time-of-flight of 100Hz. The scanCONTROL 2710 is also able to control and regulate dynamic processes.

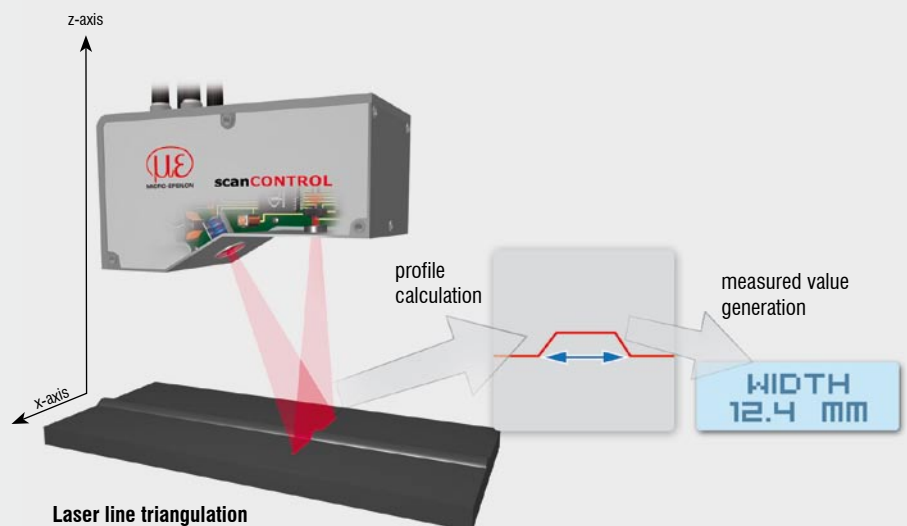

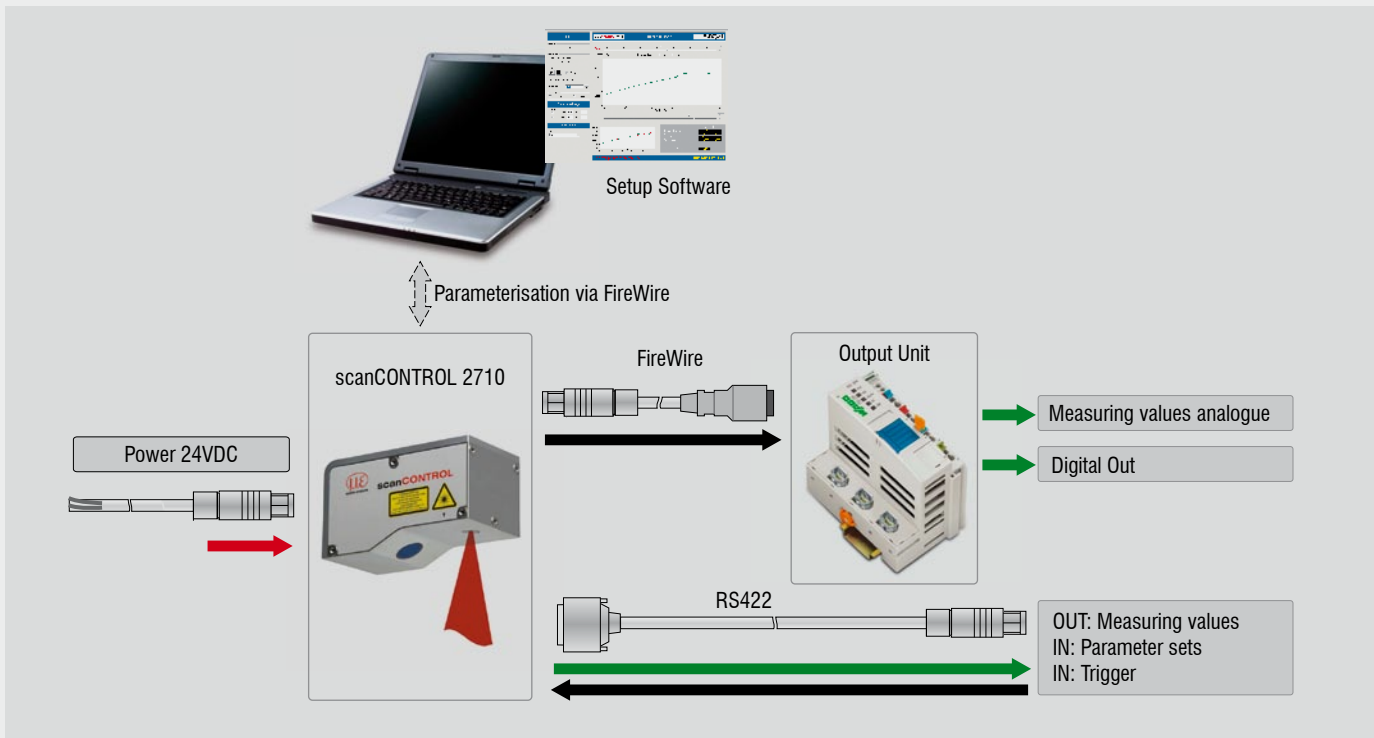

Set up Software

In order to facilitate the configuration of the sensor easier for both static and dynamic processes, profile data can be stored at full data rate using the set up software provided. The configuration of the measurement task can be carried out afterwards with the stored offline data.

The chosen parameters are transmitted to the scanCONTROL 2710 using a laptop or PC (FireWire interface). Parameters with new test criteria can therefore be generated from this.

The set up software enables the user to benefit from a variety of features provided on the scanCONTROL 2710, including sensor settings, cutting out ranges, automatic tracking on anchor points, dynamic referencing) quickly, easily and effectively.

Comparison of the scanCONTROL 2700 and scanCONTROL 2710

The scanCONTROL 2700 sensor is a system that provides purely data and profiles via FireWire to an evaluation unit (e.g. PC). The complex calculations required to acquire profile data are performed by an external evaluation unit.

In the scanCONTROL 2710, the profile data and characteristics are generated is carried out directly in the sensor. The scanCONTROL 2710 is therefore the preferred system for applications in which simple measurement tasks need to be resolved without using additional PCs or programming effort.

Extensions and enhancements for scanCONTROL 2710

As well as measured values output via RS422, switching signals and analogue measured values can also be output. This is provided by an Output Unit, which converts measurement signals into switching and analogue signals.

With the optional scanSYSTEM 2X10 unit, the user is also able to easily document and visualise measured values and to apply statistical analysis to a series of measurements. For more complex measurement processes or for integration to larger systems, scanSYSTEM provides expanded interfaces and enables the management of almost any number of different parameters.



Output Unit for signal processing



scanSYSTEM system unit for complex calculations of profile data

Applications

scanCONTROL 2710 is specially developed for measuring beads (bulges) and grooves (indentations) and operates in both stationary mode – e.g. as a fixed inline measurement unit on a conveyor system – as well as in moving processes (e.g. on a robot arm). Many other applications are provided below.

Beads, seams, grooves and gaps

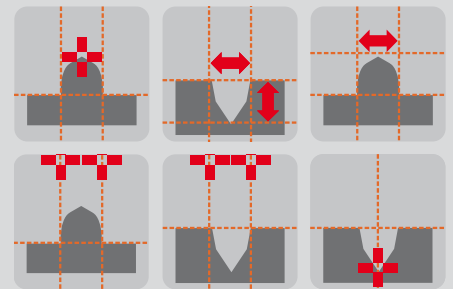
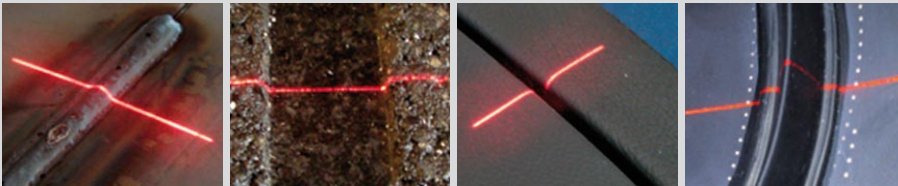

Step measurement

The sensor is based on the triangulation principle and so can also be used analogously to provide absolute distance measurement and direct step measurement.

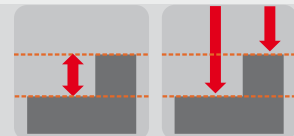
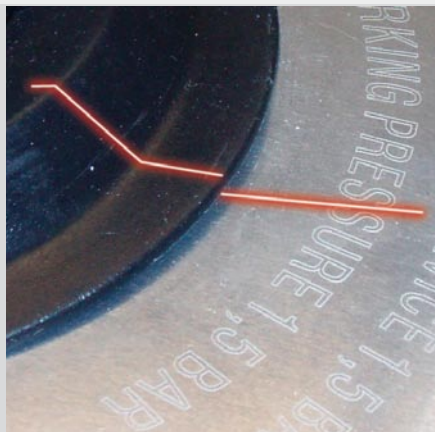

Determination of extreme values

In contrast to camera systems, scanCONTROL provides calibrated height information and so can measure position information (e.g. the highest point) directly.

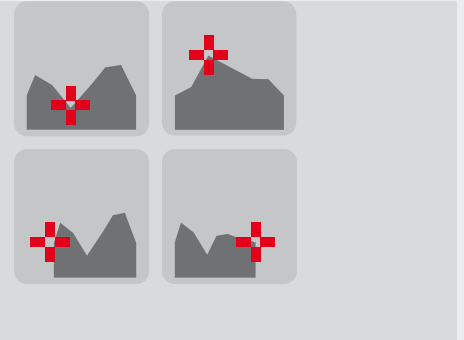

Surface defects

Defects on surfaces which do not show any contrast (e.g. cracks on rubber) can be detected by using the distance information and output directly as an OK / NOK signal.

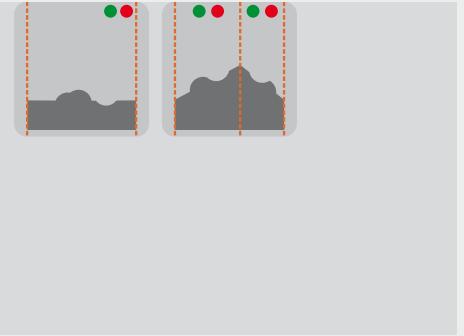
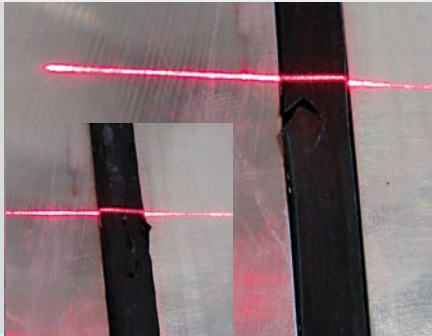

Determination of edges and position

Suitable for the tracking of edges, including unfavourable angle positions in belt vibrations. Misalignment and edge position can also be determined.

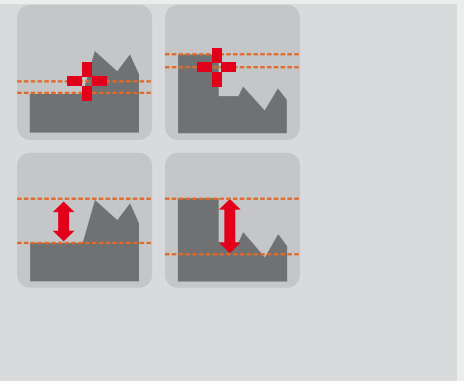
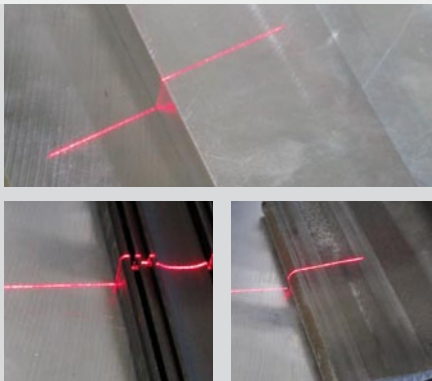

Angle measurement

The sensor enables the user to measure one or two independent angles. An intersection point can also be calculated and output. The measurement is performed by using reference straight lines, which can also be tracked automatically if the position of the target within the measuring field changes.

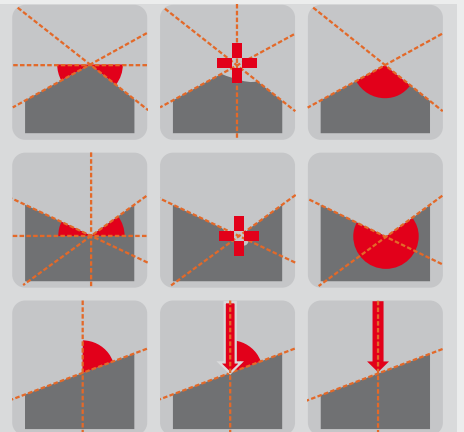
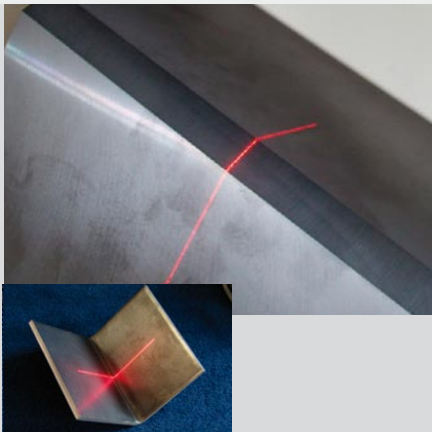

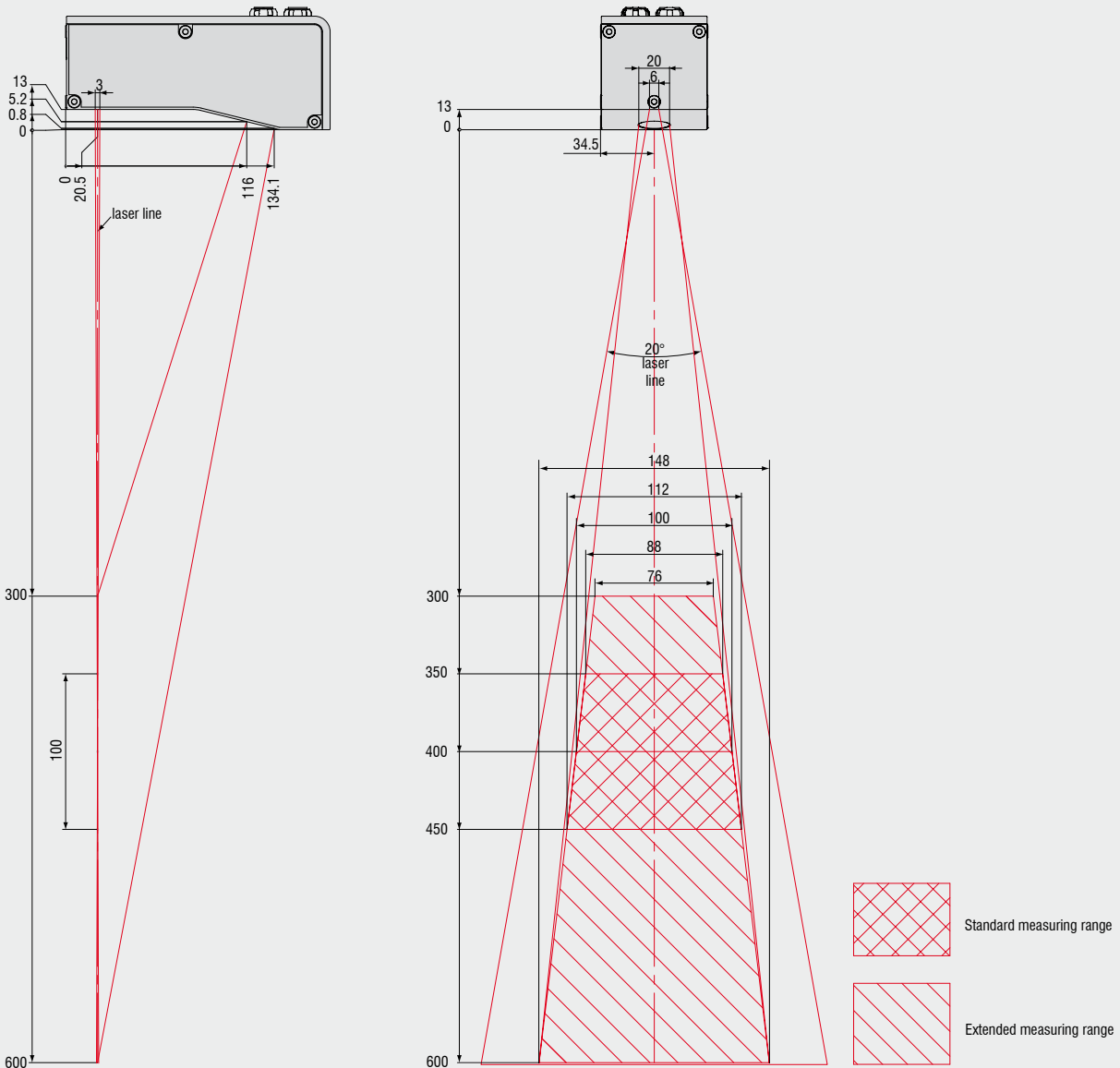
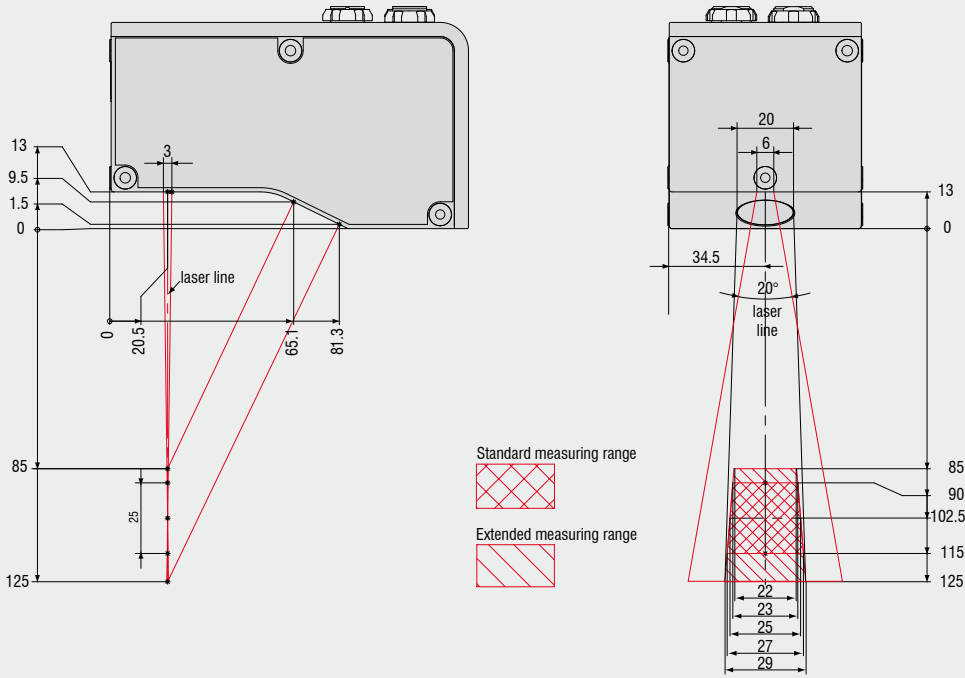

Model		scanCONTROL 2710-25	scanCONTROL 2710-100
Measuring range z-axis	standard measuring range	25mm	100mm
Start of measuring range		90mm	350mm
End of measuring range		115mm	450mm
Start of extended measuring range		85mm	300mm
End of extended measuring range		125mm	600mm
Linearity		±0.2% FSO (3σ)	
Resolution	x-axis	640 points/profile	
	reference resolution z-axis*	4μm	15μm
Profile frequency		100Hz	
Light source		semiconductor laser approx. 658nm, 20° aperture angle; standard laser class 2M: reduced 2-3 mW	
Cable length		up to 10m without hubs and full data rate, up to 50m with hubs and/or restrictions	
Protection class		IP 64	
Operating temperature		0°C to 50°C	
Storage temperature		-20°C to 70°C	
Output/Input		1x firewire, laser off (optional), 1x RS422 programmable (interface or synchronisation or encoder input)	
Display		1x laser, 1x power/error/status	
Supply		8-30VDC, 500mA	
Electromagnetic compatibility (EMC)		CE; EN 50081-2-living quarters; EN 50082-2-industrial sector	
Galvanic isolation		Only at RS422, no isolation of 24V-supply, internal circuit and FireWire bus. If isolation necessary, external 24V-DC-DC-converter required	
Weight		appr. 700 g	appr. 850 g

FSO = Full scale output

*according to a singular averaging across the measuring field (640 points)

Measuring object: Micro-Epsilon standard object (metallic, diffusely reflecting material)

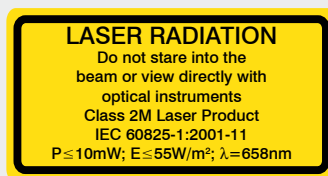

The scanCONTROL 2700 laser unit operates with a semiconductor laser featuring a wavelength of approx. 658nm (visible/red) and a 10mW optical output (laser class 2M).

Standard scope of delivery scanCONTROL 2710

- scanCONTROL 2710
- Power supply cable (4.5m)
- scanCONTROL set up software

Connecting cable for power supply and interfaces

FireWire Connecting cable

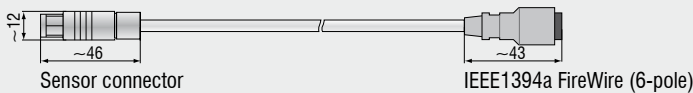

External power supply cable

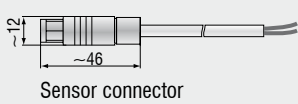

RS422 Interface cable

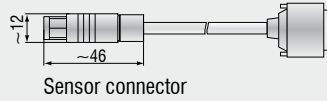

Output Unit Basic

OU fieldbus coupler

OU filter modul

Analogue output terminal

Digital output terminal

OU bus end terminal

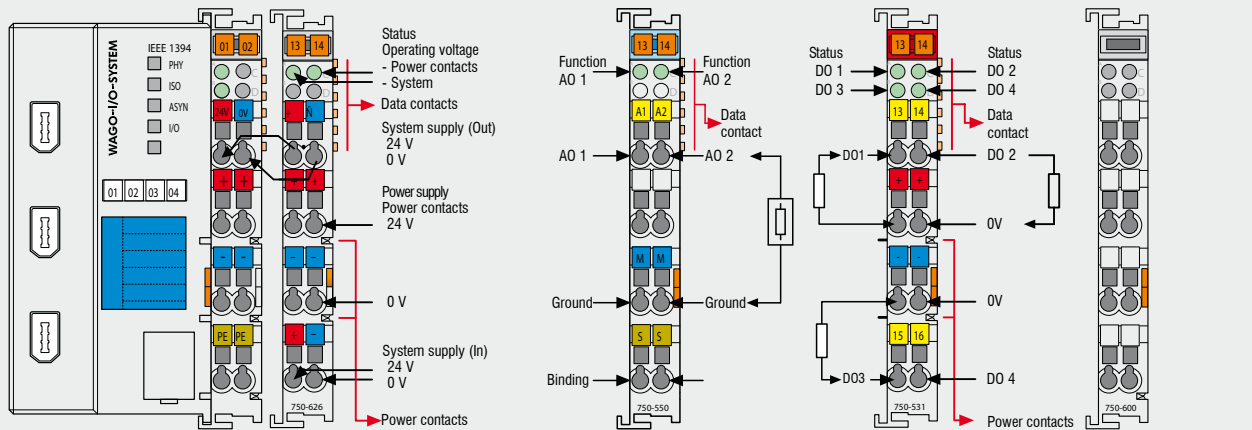

Output modules for Output Unit Basic
analogue:
 ±10V
 0-10V
 0-20mA
 4-20mA

Output modules for Output Unit Basic
digital:
 24V positive switching
 24V negative switching
 5V positive switching